

---

**PHYSICS**

**5054/31**

Paper 3 Practical Test

**May/June 2016**

**CONFIDENTIAL INSTRUCTIONS**

**Great care should be taken to ensure that any confidential information given does not reach the candidates either directly or indirectly.**

**No access to the Question Paper is permitted in advance of the examination.**

---



If you have any problems or queries regarding these Instructions, please contact Cambridge  
by e-mail: info@cie.org.uk,  
by phone: +44 1223 553554,  
by fax: +44 1223 553558,  
stating the Centre number, the nature of the query and the syllabus number quoted above.

---

This document consists of **11** printed pages and **1** blank page.

## Instructions for preparing apparatus

These instructions detail the apparatus required for each experiment in this paper. No access is permitted to the Question Paper in advance of the examination session.

## Number of sets of apparatus

In addition to a few spare sets, the minimum number of sets of apparatus to be provided should be sufficient to enable candidates to spend 20 minutes with the apparatus for each of Questions 1, 2 and 3, and one hour with the apparatus for Question 4. The order in which candidates answer the questions will be determined by the Supervisor. Candidates may spend one hour circulating around Questions 1, 2 and 3, followed by an hour on Question 4, or vice versa.

It is assumed that candidates will supply their own calculator and geometrical instruments, such as a set square,  $0^\circ$  to  $180^\circ$  protractor, pair of compasses and 30 cm rule. Candidates should be advised in advance that they may, if they wish, use quartz wristwatches with stopwatch facilities, providing that such wristwatches afford the required precision.

## Instructions for the supervision of the examination

The Supervisor, who may be a physics teacher, is responsible for the administration of the examination according to the procedures detailed in the Handbook for Centres. In all instances, a physics teacher should be present. Preferably, this teacher should have been responsible for the preparation of the apparatus. Two invigilators must be present at all times: it is not acceptable for a teacher who has been responsible for preparing the candidates for this paper to be the sole Supervisor or Invigilator.

Supervisors may make the following announcement at the start of the examination.

'The Examiners do not want you to waste time if you are unable to do any experiment. Any candidate who is unable to get results with an experiment may ask for help. The extent of the help given will be reported to the Examiners, who may make a deduction of marks.'

Supervisors should note that a candidate may only be given enough assistance to allow some raw readings or observations to be made. On no account should any assistance be given with the treatment or analysis of these readings and observations.

Supervisors may draw to the attention of the candidates any significant deviation between the apparatus provided and that detailed in the Question Paper, particularly where diagrams are given in the paper.

Candidates should be reminded that all their work should be written on the Question Paper. Rough paper must not be used.

The Supervisor must complete the Report at the back of these instructions. Details should be given of any significant deviation between the apparatus used and that specified in these Instructions. A sample set of results can often help Examiners. A copy of this Report must be included in **each** packet of scripts.

**Question 1****Items to be supplied by the Centre (per set of apparatus, unless otherwise specified)**

30 cm plastic ruler with a mm scale (see Note 1).

10 g mass.

A pivot (knife-edge) (see Note 2).

**Notes**

1. The 30 cm ruler must have a 'dead space' at each end. The 'dead space' is the small section at the end of the rule which has no scale markings. If the ruler has two scales, one of the scales must be taped over.
2. The candidates will balance the ruler on the pivot. If necessary Supervisors may have to supply a support for the pivot. A triangular glass prism or a small triangular wooden block is suitable.
3. At the changeover, Supervisors should dismantle any apparatus left set up by the candidate.

**Information required by Examiners**

Sample set of numerical results, clearly marked "Supervisor's Results", obtained out of sight of the candidates.

## Question 2

### Items to be supplied by the Centre (per set of apparatus, unless otherwise specified)

Metre rule with a hole at the 10.0 cm mark (see Note 1).

An optical pin in a cork to support the metre rule (see Note 2).

A stand, boss and clamp to hold the cork (see Note 3).

Two 100 g slotted masses.

Blu-tack (see Note 4).

A stopwatch, reading to 0.1 s or better.

### Note

1. The diameter of the hole should be slightly greater than the diameter of the head of the optical pin so that the metre rule can swing freely about the pin.
2. The pin should not bend with the metre rule and masses suspended from it. The optical pin should be pushed about 2 cm into the cork. The candidate needs to be able to remove the rule from the pin without taking the pin out of the cork.
3. The Supervisor should set up the apparatus so that the stand, boss and clamp support the pin over the edge of the bench. The metre rule should be suspended from the pin so that it overhangs the bench as shown in Fig. 2.1. The stand should not topple over when the metre rule and masses are suspended from the pin. It may be necessary to fix the stand to the bench with a G-clamp or use a weight on the base of the stand. For safety the optical pin should be held in the clamp above the candidates' eye level.

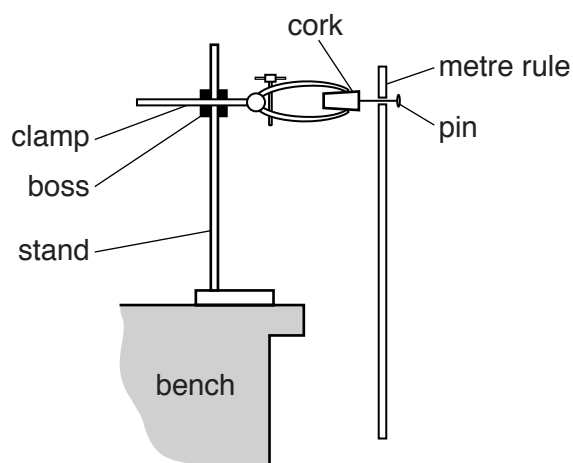

Fig. 2.1

4. The Blu-tack will be used by the candidates to attach the masses to the rule.
5. At the changeover, the Supervisor should
  - remove the masses from the rule and remove the Blu-tack from the masses and the rule.
  - ensure that the apparatus is set up as shown in Fig. 2.1.

**Information required by Examiners**

Sample set of numerical results, clearly marked “Supervisor’s Results”, obtained out of sight of the candidates.

**Question 3****Items to be supplied by the Centre (per set of apparatus, unless otherwise specified)**

250 cm<sup>3</sup> glass beaker (see Note 1).

Supply of water (see Note 2).

Optical pin in a cork.

Stand, boss and clamp to hold the optical pin in a cork.

Block (see Note 3).

Half-metre rule.

Set square.

Paper towels to mop up spillages.

**Notes**

1. A horizontal black line, of length about 5 cm and width about 1 mm, should be drawn around the outside of the beaker using a permanent marker pen. This line should be opposite the spout and just below the level of the spout (if present). The line should be labelled M. Another black line must be drawn on the base of the beaker with a permanent marker pen. This line is along the diameter, containing the spout, as shown in Fig. 3.1. The line should be 2 mm to 3 mm thick with one end of this line below the centre of line M.

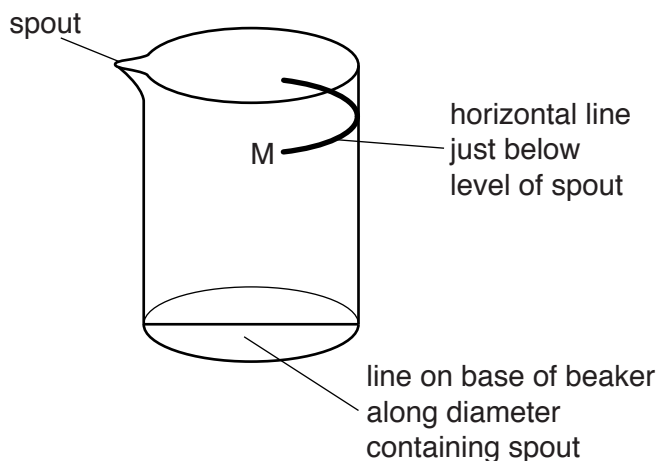
**Fig. 3.1**

2. Each candidate will need about 350 cm<sup>3</sup> of water. This may be held in a larger beaker or plastic container.
3. The block will support the beaker above the bench. The top of the block should be white. The height of the block should be just greater than the height of the lowest possible position of the optical pin in the cork when it is held in the clamp. Candidates need to be able to adjust the height of the pin so that it is level with the base of the beaker. The block can be a block of wood painted white on the top surface or a rigid white plastic tub.

- 4 At the changeover, the Supervisor should
- pour the water from the beaker back into the container and replenish the supply of water in the container, if necessary.
  - dry the area around the apparatus, if there have been any spillages.
  - dismantle any apparatus left set up by the candidate.

**Information required by Examiners**

Sample set of numerical results, clearly marked “Supervisor’s Results”, obtained out of sight of the candidates.

**Question 4****Items to be supplied by the Centre (per set of apparatus, unless otherwise specified)**

D.C. power supply (see Note 1).

Switch or plug key.

Resistor of resistance  $22\ \Omega \pm 5\%$  with a power rating of at least 1 W, labelled X (see Note 2).

Voltmeter capable of measuring a potential difference up to 5.0 V to a precision of 0.1 V or better. An analogue or digital meter is suitable (see Note 3).

Connecting leads to enable the Supervisor to set up the circuit shown in Fig. 4.1. The points A and B should be labelled and should have suitable terminals to connect to the resistors.

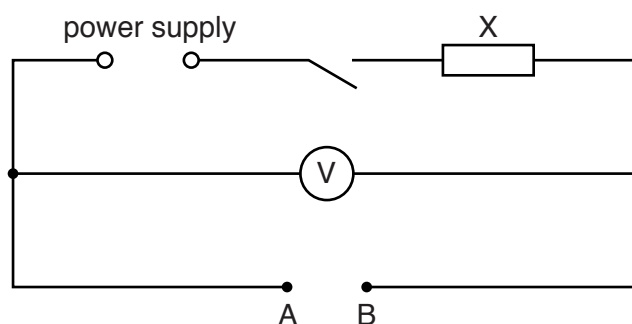

**Fig. 4.1**

Three resistors of resistances  $10\ \Omega$ ,  $22\ \Omega$  and  $39\ \Omega$ , each  $\pm 5\%$  and with a power rating of at least 0.5 W (see Note 4).

If required additional connecting leads to enable the **candidate** to connect up to three resistors in series or two resistors in parallel between A and B.

**Notes**

- The following are suitable power sources but all the candidates at a centre must be supplied with the same type of source:
  - three 1.5 V dry cells in suitable holders connected in series,
  - four 1.2 V rechargeable cells in suitable holders connected in series,
  - d.c. power supply of 4 V or 5 V.
 If a variable d.c. power supply is used, the variable control should be taped to prevent candidates altering the output voltage.
- The resistor should have suitable terminals to enable it to be connected into the remainder of the circuit. The value of the resistor should be obscured from the candidates and the resistor should be labelled X. e.g. RS product code 707-8606.
- The Supervisor should ensure that it is possible to measure the e.m.f. of the power supply with the voltmeter. If the voltmeter reading is off scale then the e.m.f. of the power supply should be reduced.



4. The resistors should have suitable terminals to enable them to be connected into the remainder of the circuit. The Supervisor should label the resistors with their nominal values i.e.  $10\ \Omega$ ,  $22\ \Omega$  and  $39\ \Omega$  appropriately. The power rating of the resistors should be at least  $0.5\text{W}$ . The RS product codes of suitable resistors are:  
 $10\ \Omega$  RS 707-8063  
 $22\ \Omega$  RS 707-8097  
 $39\ \Omega$  RS 707-8110
5. Before the start of the experiment and at the changeover, the Supervisor should set up the circuit as shown in Fig. 4.1. The additional resistors and the additional connecting leads (if present) should be laid out on the bench.

#### **Information required by Examiners**

Type and e.m.f. of power source, e.g. dry cells,  $4.5\text{V}$ .

Sample set of numerical results, clearly marked "Supervisor's Results", obtained out of sight of the candidates.

**BLANK PAGE**

---

Permission to reproduce items where third-party owned material protected by copyright is included has been sought and cleared where possible. Every reasonable effort has been made by the publisher (UCLES) to trace copyright holders, but if any items requiring clearance have unwittingly been included, the publisher will be pleased to make amends at the earliest possible opportunity.

To avoid the issue of disclosure of answer-related information to candidates, all copyright acknowledgements are reproduced online in the Cambridge International Examinations Copyright Acknowledgements Booklet. This is produced for each series of examinations and is freely available to download at [www.cie.org.uk](http://www.cie.org.uk) after the live examination series.

Cambridge International Examinations is part of the Cambridge Assessment Group. Cambridge Assessment is the brand name of University of Cambridge Local Examinations Syndicate (UCLES), which is itself a department of the University of Cambridge.

**This form must be completed and returned with the candidates' scripts.**

### REPORT ON PRACTICAL PHYSICS

The Supervisor is asked to give the following details, using the space provided on page 12.

- (a) Information required at the end of the test, as indicated in the Instructions.
- (b) Any help given to a candidate.
- (c) Any general difficulties encountered in preparing the apparatus.
- (d) Any difficulties experienced by particular candidates. These should include reference to difficulties due to faulty apparatus or materials and accidental damage to apparatus or materials. Candidates should be identified by name and candidate number.

Other cases of hardship, such as disability or illness, should be reported to Cambridge in the normal way.

The Supervisor is asked to provide a plan of the work benches, giving details by candidate numbers of the places occupied by the candidates for each session. The plan and report should be enclosed in the envelope containing the candidates' scripts. If more than one envelope is used, a copy of the report must be enclosed in each envelope.

#### Declaration to be signed by the Principal

The preparation of this practical examination has been carried out so as to maintain fully the security of the examination.

Signed .....

Name (in block capitals) .....

Centre number .....

Centre name .....



**Information required**

1. Type and e.m.f. of power source used in Question 4.

.....

2. For each question, please enclose a sample set of numerical results, obtained out of sight of the candidates and clearly labelled "Supervisor's Results".

**Details of difficulties and any help given to candidates**

